

**SPECIFICATIONS**

**Short Form Specs**

Winston Collectramatic high efficiency pressure fryer, model PF46 or PF56 with drain valve indicator, and a 13" deep collector, which allows more than 1000 pieces to be cooked without manual filtration or emptying collector. Available with quarter rack basket or traditional clamshell basket.

**Construction**

**Control**

PF46C and PF56C models include Winston 8-channel control  
PF46F and PF56F models include FAST® VC210 control (extra charge)

**Capacity**

PF46  
4-Head - 14 lbs. (6.35 kg) product  
64 lbs. (28.8 kg) or 8.15 g (30.85L) cooking oil

PF56  
6-Head - 18 lbs. (8.2 kg) product  
75 lbs. (33.8 kg) or 9.55 g (36.15L) cooking oil

**Electrical**

Refer to wiring schematic included in equipment for installation assistance. Cord/Plug not included. Licensed electrician may be required. Check local codes.

**Materials**

To be 16 - 20 gauge stainless steel mounted on four adjustable legs. Cooking vessel to be constructed of stainless steel.

**Insulation**

Full 1-1/2" insulation around the cooking vessel.

**Load Limits**

Maximum of 14 lbs. (LP46) or 18 Lbs. (LP56) of frozen or refrigerated chicken, fish, meats, or vegetables per load.

**Installation Requirements**

Ventilation required. Check local codes.



**PF46 & PF56**  
COLLECTRAMATIC®  
HIGH EFFICIENCY FRYER



*Collectramatic High Efficiency Pressure Fryers are the workhorses of any kitchen and can cook up to 120 deliciously golden-brown fried chickens without filtration.*



COLLECTRAMATIC

WINSTON FOODSERVICE

2345 Carton Drive | Louisville, KY 40299 USA  
winstonfoodservice.com | 800.234.5286 | +1.502.495.5400

Specifications subject to change without notice.

JOB

ITEM#

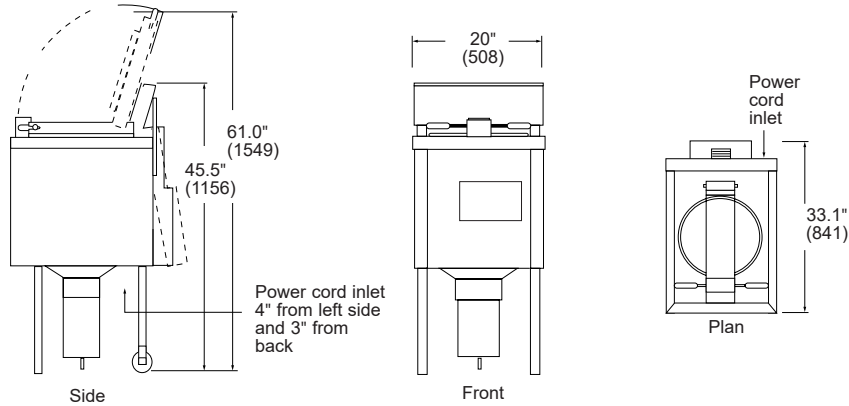

capacity	size in (mm)	volts	hertz	ph	amps	watts	circuit amps	ship wt. lb (kg)	ship cube
<b>PF46</b> 4-Head 14 lbs. (6.35 kg) product 64 lbs. (28.8 kg), or 8.15 g (30.85L) cooking oil	H= 45.5" (1156) H2= 61.0" (1549) W= 20" (508) D= 33.1" (841)	US / CANADA							
		208	60	3	29.2	10500	50	204 (93)	20.0 (0.57)
		240	60	3	25.2	10500	50		
		240	60	1	43.7	10500	60		
		INTERNATIONAL							
		400*	50	3	N/A	10500	N/A	204 (93)	call factory
<b>PF56</b> 6-Head 18 lbs. (8.2 kg) product 75 lbs. (33.8 kg), or 9.55 g (36.15L) cooking oil	H= 45.5" (1156) H2= 61.0" (1549) W= 20" (508) D= 33.1" (841)	US / CANADA							
		208	60	3	29.2	10500	50	220 (100) 20.0 (0.57)	
		240	60	3	25.2	10500	50		
		240	60	1	43.7	10500	60		
		INTERNATIONAL							
		400*	50	3	N/A	10500	N/A	220 (100)	call factory

H= Height w/lid closed • H2= Height w/lid open • Includes: 1 clamshell basket, 1 drain hook, 1 pair gloves, 1 spatula, 2 collector gaskets, 2 lid gaskets, 1 Teflon® brush, 1 long collector, 1 heat plate • Cord and plug not included

**OPERATIONAL EXCELLENCE** the Collectramatic fryer has the largest cold zone in the industry and can perform 20-30 cook cycles without filtration, which extends shortening life and reduces filtering downtime. If speed of service is important, the fryer's heat curve can be adjusted to cook up to 18 lbs. of fried chicken in as little as ten minutes. Utilizing Winston's Quarter Rack basket system improves labor efficiencies because the chicken is cooked on racks and moved directly into the holding cabinet with minimal handling.

**EASY-TO-USE CONTROLS** -Collectramatic fryers are offered using the KFC approved 8 channel Winston control or FAST VC210 20 channel control.

**BUILT TO LAST WITH QUALITY CRAFTSMANSHIP**, the cylindrical cooking pot of the Collectramatic fryer is constructed to last for many years. Each fryer is built with high grade stainless steel and uses very few moving parts.

**WARRANTY.** Winston provides a standard limited warranty of two year on parts and two year on labor. Winston does not warrant FAST controls. Warranty disclaimer for failure to clean. Ask for complete warranty disclosure.

**SPECIFY THE FOLLOWING WHEN ORDERING:**

Standard (No additional cost):

1. Model number.
2. Voltage Preference: 208V or 240V for US or Canada. Cordset is not included.
3. Control Type C = Winston, F= Fast VC210\* (extra charge)
4. Quarter Rack Basket or Clamshell basket
5. Drain Valve Indicator

\*Inquire about additional international voltages available.

Standard (No additional cost):

- |                     |               |
|---------------------|---------------|
| 1 Clamshell basket  | 1 Drain Hook  |
| 2 Collector gaskets | 2 Lid gaskets |
| 1 Teflon brush      | 1 Spatula     |

Accessories & Supplies (Additional cost):

- |                                   |                               |
|-----------------------------------|-------------------------------|
| PS1180 Utensil rack               | PS1290 Open basket            |
| PS2838 Qtr rack basket, 4-hd      | PS2839 Qtr. rack basket, 6-hd |
| PS2837/25 Qtr rack basket shelves | PS3120 Store accessory kit    |

**FOR WINSTON SERVICE PARTS, ACCESSORIES, AND SUPPLIES ONLINE!**  
foodservice.winstonind.com/parts-supplies



COLLECTRAMATIC

WINSTON FOODSERVICE

2345 Carton Drive | Louisville, KY 40299 USA  
winstonfoodservice.com | 800.234.5286 | +1.502.495.5400

Specifications subject to change without notice.